

KUFO/SECO DUST COLLECTOR



UFO-101DC

2HP / 110V / 220V / 60HZ / 1PH / 3PH DUST COLLECTOR

- **Caution:** This Dust Collector is designed to Collect Wood Working Dusts only. Use of this product to remove any other types of dust will **VOID THE WARRANTY.** We offer other models of dust collectors to be used with more abrasive dusts and powders. Please, contact us @ 888-558-4628 for specific recommendations.
- **Caution:** The machine operator should carefully read and understand the owner's manual before operating this machine! Also, the manufacturer is not responsible for any damages or injuries caused by any modifications to machine
- **Caution:** Before you turn on the dust collector, please, make sure the motor is **Single Phase or Three Phase.**

KUFO/SECO DUST COLLECTOR

Connection diagram

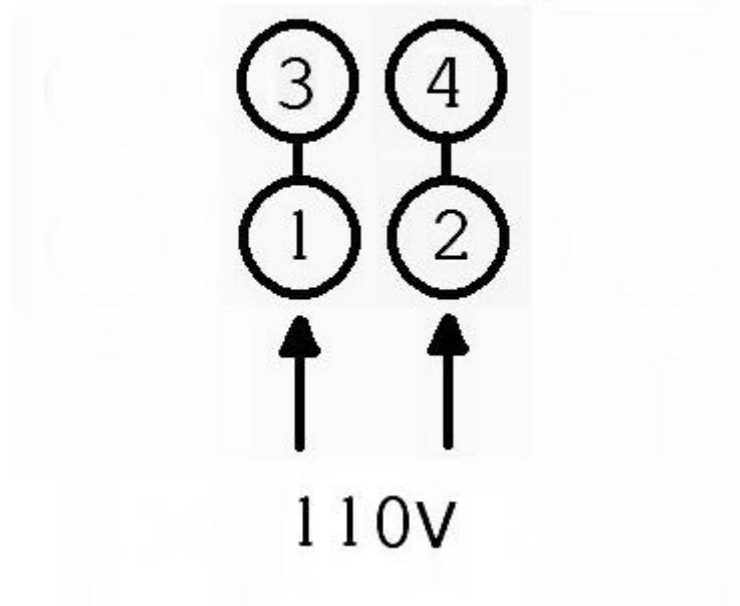

If your Dust Collector is 110V / Single Phase, please, read the following information carefully!

- **This Dust Collector is wired for 220V / Single Phase use only.**
- See the wiring diagram for the proper wiring voltage for your use. Please note: Be sure the **Ground Wire** is securely attached to the motor body for 220V wiring. Please Contact Us Toll Free @ 888-558-4628, if you need additional information, before starting the machine.
- **CAUTION:**
 1. This Dust Collector UFO-101 use 110V only. UFO-101 does not have a dual voltage motor and cannot be run on 220 volt power.
 2. The machine operator should carefully read and understand the owner's manual before operating this machine! Also, the manufacturer is not responsible for any damages or injuries caused by any modifications to machine.

KUFO/SECO DUST COLLECTOR

Connection diagram

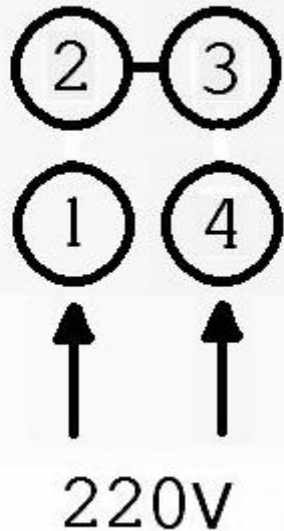

If your Dust Collector is 220V / Single Phase, please, read the following information carefully!

- **This Dust Collector is wired for 220V / Single Phase use only.**
- See the wiring diagram for the proper wiring voltage for your use. Please note: Be sure the **Ground Wire** is securely attached to the motor body for 220V wiring. Please Contact Us Toll Free @ 888-558-4628, if you need additional information, before starting the machine.
- **CAUTION:**
 3. Dust Collector UFO-101 use 220V only. UFO-101 does not have a dual voltage motor and cannot be run on 110 volt power.
 4. Dust Collector UFO-101 (UL) use 240V only. UFO-101 (UL) does not have a dual voltage motor and cannot be run on 110 volt power.
 5. The machine operator should carefully read and understand the owner's manual before operating this machine! Also, the manufacturer is not responsible for any damages or injuries caused by any modifications to machine

KUFO/SECO DUST COLLECTOR

If your Dust Collector is three phase, please, read following information carefully!

Connection diagram

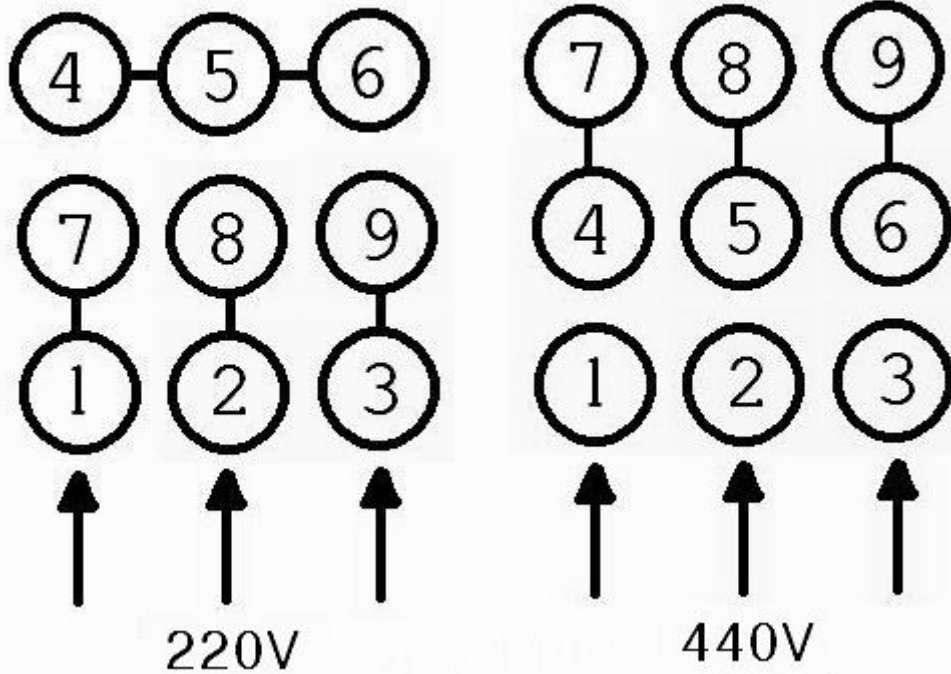

- **This Dust Collector is Pre-wired for 220V / 3 Phase use.**
- See the wiring diagram for the proper wiring voltage for your use. Please note: Be sure the **Ground Wire** is securely attached to the motor body for either 220V or 440V wiring. Please Contact Us Toll Free @ 888-558-4628, if you need additional information, before starting the machine.
- **Caution:** The machine operator should carefully read and understand the owner's manual before operating this machine! Also, the manufacturer is not responsible for any damages or injuries caused by any modifications to machine

*** Wiring Instructions for 220V / 440V / three phase motor ***.

KUFO/SECO CARTRIDGE FILTER



DC-19C

PARTS LIST (US)

PART NO.	DESCRIPTION	SIZE	Q'TY
1	CARTRIDGE FILTER	19" DIAMETER	1
2	HANDLE		1
3	UPPER BAG STRIP	64-1/2" X 5/8"	1
4	LOWER BAG STRIP	63" X 5/8"	1
5	PLASTIC BAG	19" X 39-3/8"	1

PARTS LIST (EU)

PART NO.	DESCRIPTION	SIZE	Q'TY
1	CARTRIDGE FILTER	48cm DIAMETER	1
2	HANDLE		1
3	UPPER BAG STRIP	1600mm X 16mm	1
4	LOWER BAG STRIP	1640mm X 16mm	1
5	PLASTIC BAG	480mm X 1000mm	1

UFD-101DC

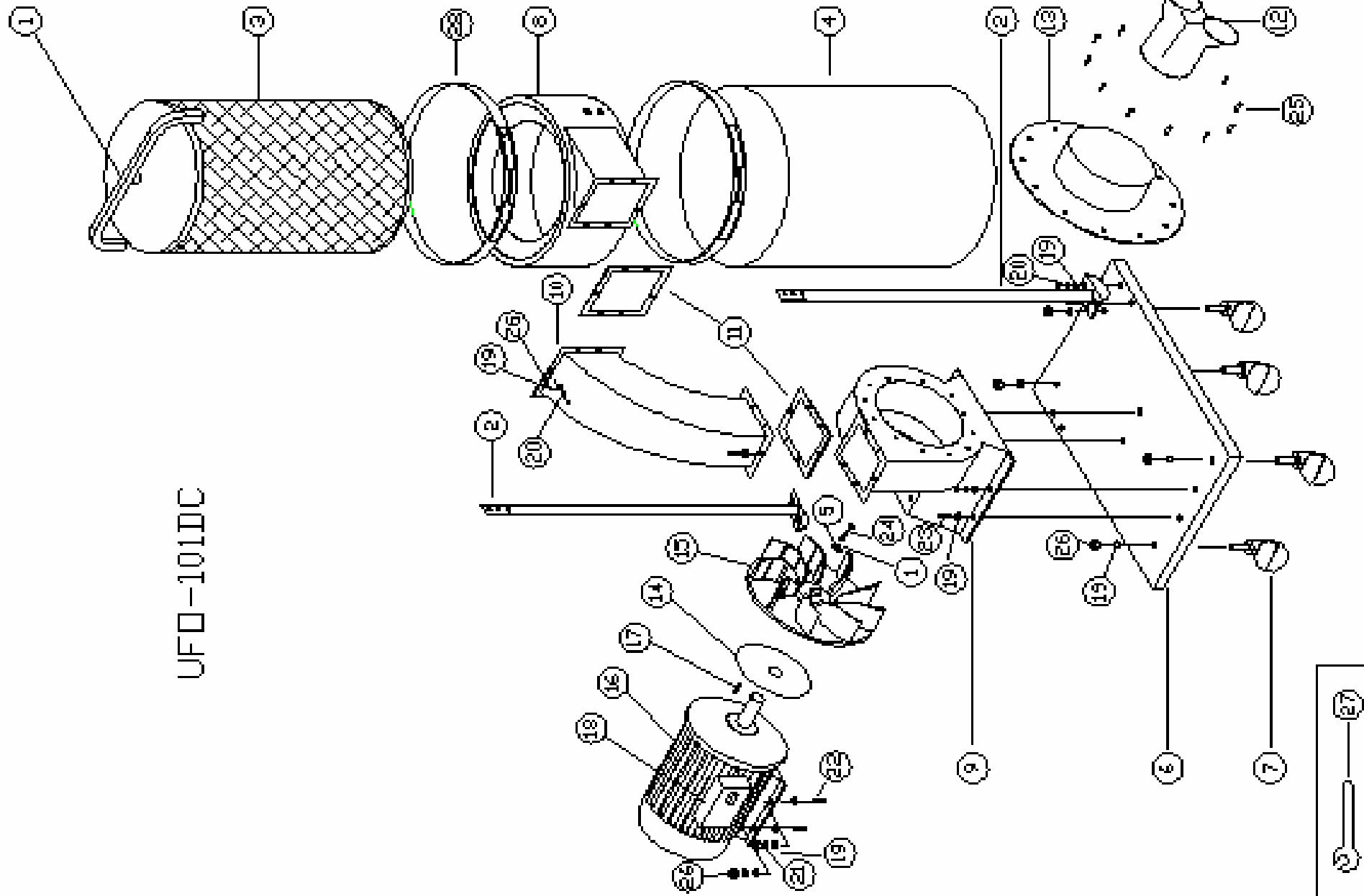

KUFO/SECO DUST COLLECTOR

UFO 101DC							
ITEM	DESCRIPTION	SIZE	Q'TY	ITEM	DESCRIPTION	SIZE	Q'TY
1	Handle	1/2" *1.0mm *950mm	1	15	Fan		1
2	Bag support	7/8" *1.2mm *865mm	2	16	Motor	2HP	1
3	Cartridge filter	152cm*100cm	1	17	Key		1
4	Plastic bag	152cm*80cm	1	18	Switch		1
5	Spring washer	5/16"	1	19	Washer	5/16"	32
6	Base plate	21.5"*31.5"*1.5"	1	20	Screw	5/16"*1/2"	20
7	Caster	2"φ	4	21	Spring washer	5/16"	4
8	Collector		1	22	Screw	5/16"*1"	4
9	Collector body	6.5*8"*5"	1	23	Screw	5/16"*3/4"	4
10	Connector		1	24	Screw	1/4"*1"	1
11	Gasket	8"*6.5"	2	25	Screw	1/4"*3/8"	12
12	Inlet	5"φ	1	26	Nut	5/16"	20
13	Inlet cover	5"φ	1	27	Wrench		1
14	Gasket		1	28	Upper bag strip	64-1/2" X 5/8" (1640mm X 16mm)	2